

High Performance Oscillating Fan

Owner's Guide

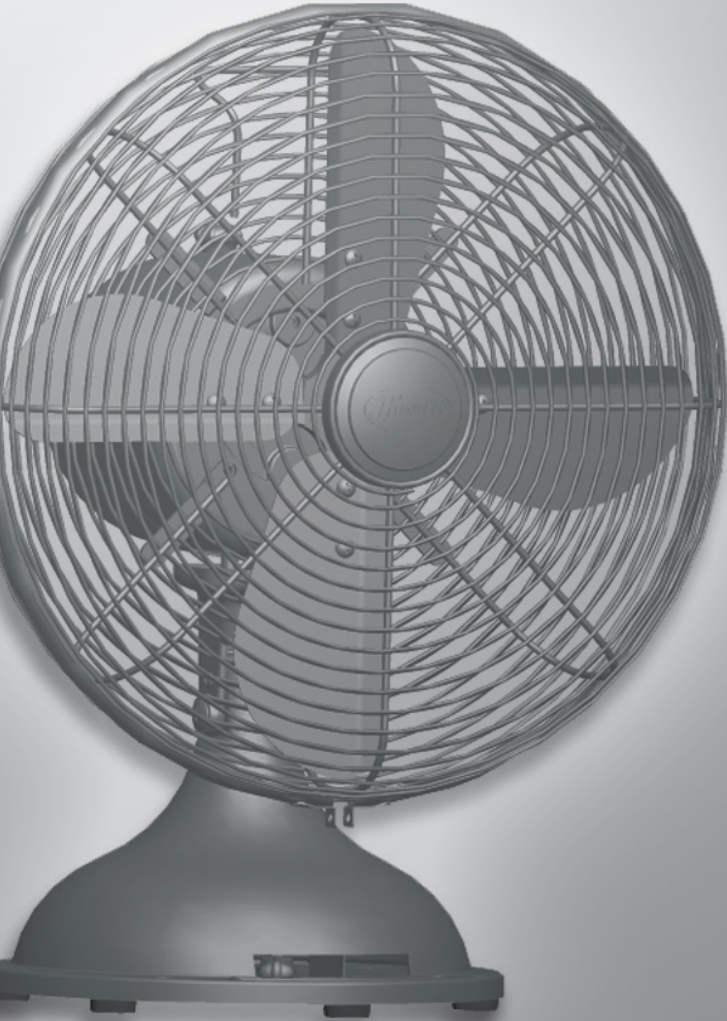

English

Models
90400
90406

44826-01
20111014
©2011 Hunter Fan Co.

SINCE 1886
Hunter[®]

IMPORTANT SAFETY INFORMATION

Read & Save These Instructions

WARNING

To reduce the risk of fire or electrical shock, **DO NOT** use this fan with any solid-state speed control device.

CAUTION

When using electrical appliances, basic precautions should always be taken to reduce the risk of fire, electric shock and personal injury:

1. Read all instructions before using this fan.
2. Improper installation may result in the risk of fire, electric shock or personal injury.
3. To prevent the risk of fire and electric shock, **DO NOT** use the unit near windows. Rain and moisture may create an electrical hazard.
4. The power plug must be removed from the power socket when not in use, before cleaning, servicing, maintenance and before moving to another location.
5. **DO NOT** put fan in a damp place or where humidity is high—such as a bathroom.
6. The fan should be placed on a flat, stable surface or tabletop to avoid overturning.
7. Use fan only for intended use, as described in this instruction manual.
8. To protect against electrical shock, **DO NOT** immerse unit, plug or cord in water or spray with liquids.
9. Close supervision is necessary when any appliance is used by or near children.
10. **NEVER** insert fingers, pencils or any other objects through the grill when the fan is running.
11. **DO NOT** operate any appliance with a damaged cord or plug, after the appliance malfunctions or has been dropped or damaged in any manner.
12. To disconnect, grip plug and pull from wall outlet. **NEVER** yank on cord.
13. **ALWAYS** use on a dry surface.
14. This product is intended for household use only and not for commercial or industrial use.
15. **DO NOT** operate fan in the presence of explosive and/or flammable fumes.
16. **DO NOT** place fan or any parts near an open flame, cooking or any other heating appliances.
17. **DO NOT** use near curtains, plants, window treatments, etc.
18. This appliance has a grounded three-prong plug and is suitable for grounded receptacle use only. An adapter is available for connecting three-blade grounding-type plugs to two-slot receptacles. The adapter must be properly grounded. **DO NOT** attempt to defeat the purpose of this safety feature.
19. The rubber feet on this product may interact with wood and cause damage to furniture. Do not place on fine wood furniture.

WELCOME

Thank you for choosing the Hunter Millennium™ Table Fan. This manual gives you complete instructions for using your fan. Here are some the features you will enjoy with your fan:

- An attractive design that enhances any decor
- A powerful Hunter motor for maximum air flow
- Three speeds to adjust your comfort level

Before installing your fan, record the following information for your records and for warranty assistance.

Model Name _____

Date Code _____

Date Purchased _____

Where Purchased _____

Please attach your receipt or a copy of your receipt to this manual for future reference.

UNPACKING

As you unpack the fan, save the carton and packing materials in case you want to move or ship the unit in the future.

Carefully remove all items from the box.

NOTE: It is best to have someone hold the box while you lift the fan and the protective packaging out of the carton.

Make sure all shipping materials are removed from fan before operating.

GROUNDING INSTRUCTIONS

This appliance is for household use only and may be plugged into any 120-volt AC electrical outlet (ordinary household current). DO NOT use any other type of outlet.

⚠ WARNING

This unit is suitable for grounded receptacle use only.

The cord has a grounded plug as shown in Figure 1. An adapter, as shown in Figure 2, is available for connecting three-blade grounding-type plugs to two-slot receptacles. The green grounding lug extending from the adapter must be connected to a permanent ground such as a property grounded outlet box. The adapter should not be used if a three-slot grounded receptacle is available.

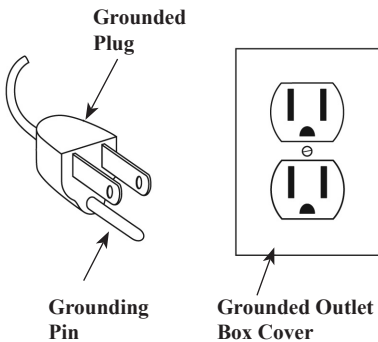

FIGURE 1

LINE CORD SAFETY TIPS

1. NEVER pull or yank on the cord or the appliance.
2. To insert plug, grasp it firmly and guide it into the outlet.
3. To disconnect the appliance, grasp the plug and remove it from the outlet.
4. Before each use, inspect the line cord for cuts and/or abrasion marks. If any are found, the appliance should be serviced and the line cord replaced. Please return it to our Service Department or to an authorized service representative.
5. NEVER wrap the cord tightly around the appliance, as this could place undue stress on the cord where it enters the appliance and could cause it to fray and break.
6. DO NOT operate appliance if the line cord shows any damage, if the appliance works intermittently or stops working entirely.

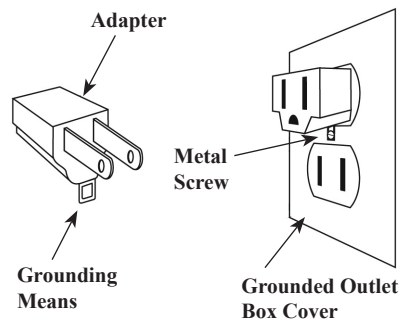

FIGURE 2

FUSED PLUG

This plug is a safety feature. It contains a safety device (fuse) that should not be removed. Discard product if the attachment plug is damaged. To reduce the risk of fire, electric shock and personal injury, DO NOT remove, replace, repair or tamper with the originally supplied plug. If the fan does not function properly, it may be due to the safety device incorporated in this plug. If the fuse fails, it is generally due to a short circuit or circuit overload. Replace the fuse as per the instructions below. **If the replacement fuse fails, immediately unplug the unit and contact our technical support department for assistance.**

Fuse Replacement:

1. To replace the fuse, first turn the unit off and unplug it from the wall. Locate the door on top of the plug. Figure 1.
2. Slide the door on top of the plug towards the blades. Figure 2.
3. Carefully remove the fuse from the clips holding it on the top and bottom. Figure 3.

Warning! Electrical Hazard! Only replace with a fuse type and rating matching what was removed from the product.

4. Gently push the fuse back into the pins that will hold it in place.

Note: If the fuse is not seated properly, the unit will not function.

5. Slide the door back over the fuse box in the plug.
6. Plug the fan back in and resume use.

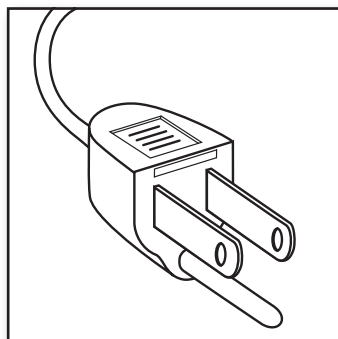

Figure 1

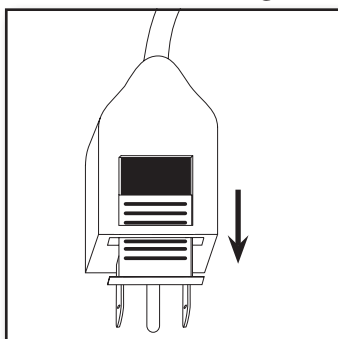

Figure 2

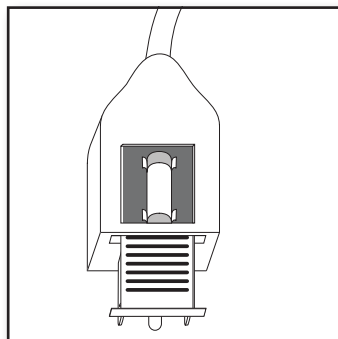

Figure 3

OPERATION

This appliance is for household use only.

1. Place the fan on a dry, safe, flat surface where it cannot fall or be pulled by the cord.
2. Plug the fan into a grounded 120-volt AC electrical outlet (ordinary household current). DO NOT use any other type of outlet. Make sure that the rated voltage of the fan is the same as the power source before plugging it into the power source.
3. Turn the fan "ON" or "OFF" by turning the Power/Speed Control knob. The power should always be OFF before unplugging the fan.
4. To select the speed, turn the Power/Speed Control knob from OFF to the desired speed setting: O (off), III (High), II (Medium), I (Low).
5. To control the upward and downward direction of airflow, loosen the screw on the side of the fan housing neck. Adjust to the desired angle and tighten the screw.
6. To make the fan oscillate, push the oscillation knob down. To stop oscillating, pull the oscillation knob up. The oscillation knob is located on the top of the fan housing, near the handle.

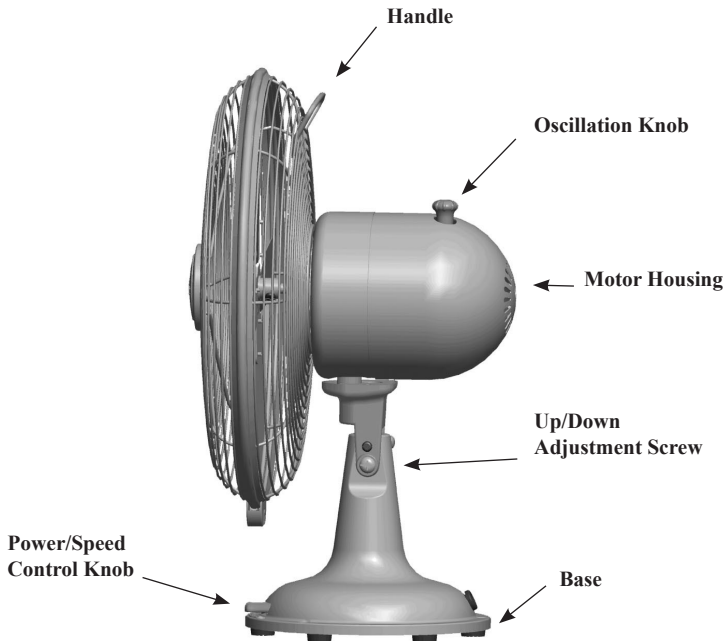

FIGURE 3

MAINTENANCE

This fan is permanently lubricated and will not require additional lubrication (oil) for the life of the fan.

This fan requires little maintenance and contains no user serviceable parts. DO NOT try to fix it yourself. Contact qualified service personnel if servicing is needed.

TO CLEAN:

1. Before cleaning, turn fan off and unplug from electrical outlet. Wipe off excess dust with a lint free cloth.
2. To ensure adequate air circulation to the motor, keep vents located at the rear of the motor housing free from dust accumulation. A vacuum cleaner hose can be used to clean these vents.
3. DO NOT immerse the fan in water or any other liquid.

CLEANING GRILL AND BLADE:

1. Turn the fan off and unplug from the electrical outlet.
2. Disassemble grills by carefully removing the screw on the bottom of the ring. See Figure 4.
3. Remove the ring.

4. Use a dry or slightly damp lint free cloth to clean the fan.
5. Use a soft, slightly damp cloth to wipe the remaining fan parts.
6. DO NOT allow water or any other liquid to get into the motor housing or base.
7. Reassemble the fan after blades and grills have dried completely. Align the grills, replace the ring, and replace the screw.
8. DO NOT plug fan into an electrical outlet until it has been fully reassembled.

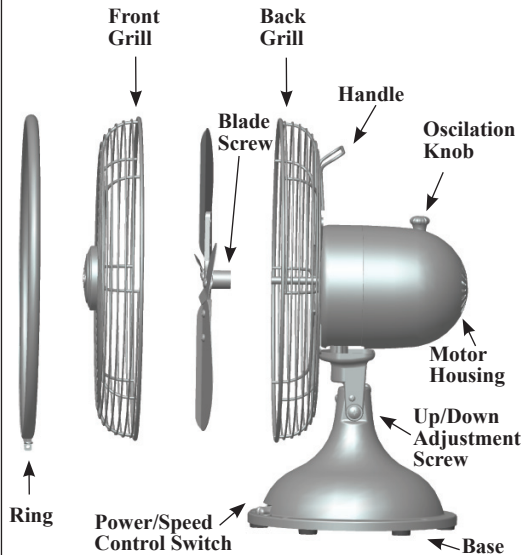

FIGURE 4

1. Disassemble and clean fan before storing.
2. Keep the original packaging for the purpose of storing the fan.
3. ALWAYS store the fan in a dry place.
4. NEVER store the fan while it is still plugged in.
5. NEVER wrap the cord tightly around the fan.
6. DO NOT put any stress on the cord where it enters the fan, as it could cause the cord to break.

PROBLEM

- Fan will not oscillate.

SOLUTION

- Push down on knob on top of motor housing to activate oscillation.

PROBLEM

- Can not adjust the angle of the fan.

SOLUTION

- Loosen the screw on the side of the fan neck. Adjust to the desired angle and tighten the screw.

If you have tried these troubleshooting solutions and still have trouble, call 1-888-830-1326 (For CAN: 1-866-268-1936) or visit our website at <http://www.hunterfan.com>.

WARRANTY

The Hunter Fan Company makes the following limited warranty to the user or consumer purchaser of this Hunter Portable fan:

If your Hunter Portable Fan motor fails at any time within five years after the date of sale to you due to a defect in material or workmanship, labor to repair the defect will be provided free of charge at our nearest service center or our Service Department in Memphis, Tennessee. You will be responsible for labor costs after this one-year period. The foregoing limited warranty applies only to the motor itself, and does not apply to electronic controls such as remote controls, remote control receivers or transmitters used in conjunction with the motor. These electronic control items are included in the one year limited warranty below.

If any part of your Hunter Portable Fan other than the motor fails at any time with one year after the date of sale to you due to a defect in material or workmanship, we will repair or, at our option, replace the defective part free of charge for parts and labor performed at our nearest service center or at our Service Department in Memphis, Tennessee.

IF THE USER OR CONSUMER PURCHASER CEASES TO OWN THE FAN, THIS WARRANTY AND ANY IMPLIED WARRANTY WHICH THEN REMAINS IN EFFECT, INCLUDING BUT NOT LIMITED TO ANY IMPLIED WARRANTY OF MERCHANTABILITY

OR FITNESS FOR A PARTICULAR PURPOSE, ARE VOIDED. NO WARRANTY, EXPRESSED OR IMPLIED, INCLUDING ANY WARRANTY OF MERCHANTABILITY OR FITNESS FOR A PARTICULAR PURPOSE, IS MADE IN RESPECT TO THE GLASS GLOBES OR LIGHT BULBS OR THE FINISH ON ANY METAL PORTION OF THE FAN. THIS WARRANTY IS IN LIEU OF ALL OTHER EXPRESS WARRANTIES. THE DURATION OF ANY IMPLIED WARRANTY, INCLUDING, BUT NOT LIMITED TO ANY IMPLIED WARRANTY OF MERCHANTABILITY OR FITNESS FOR A PARTICULAR PURPOSE, IN RESPECT TO ANY HUNTER FAN MOTOR OR OTHER FAN PART, IS EXPRESSLY LIMITED TO THE PERIOD OF THE EXPRESS WARRANTY SET FORTH ABOVE FOR SUCH MOTORS AND OTHER PARTS.

This warranty is voided if your Hunter Fan is not purchased and used in the USA.

This warranty excludes and does not cover defects, malfunctions or failures of any Hunter Portable fan which were caused by repairs by persons not authorized by us, use of parts or accessories not authorized by us, mishandling, improper installation, modifications, or damage to the Hunter Portable fan while in your possession, or unreasonable use, including failure to provide reasonable and necessary maintenance.

To obtain servicing, contact the nearest Hunter authorized service center or the Hunter Fan Company Service Department, 7130 Goodlett Farms Pkwy. Suite 400, Memphis, Tennessee 38016. Please contact us before shipping your fan to us. If we authorize you to ship it to us, you will be responsible for all insurance and freight or other transportation charges to our factory service center. We will return your Hunter Fan freight prepaid. Your portable fan should be properly packed to avoid damage in transit since we will not be responsible for any such damage. Proof of purchase is required when requesting warranty service. The purchaser must present sales receipt or other document that establishes proof of purchase.

IN NO EVENT SHALL HUNTER FAN COMPANY BE LIABLE FOR CONSEQUENTIAL OR INCIDENTAL DAMAGES.

SOME STATES DO NOT ALLOW LIMITATIONS ON HOW LONG AN IMPLIED WARRANTY LASTS OR THE EXCLUSION OR LIMITATION OF INCIDENTAL OR CONSEQUENTIAL DAMAGES SO THE ABOVE LIMITATION MAY NOT APPLY TO YOU.

THE WARRANTY GIVES YOU SPECIFIC LEGAL RIGHTS AND YOU MAY ALSO HAVE OTHER RIGHTS WHICH VARY FROM STATE TO STATE.

Hunter[®]
SINCE 1886